

Wideband Monopole Antenna for WLAN Applications

Muhammad Umar, Nabeel Hayat Khan, Usman Ali
Dept. of Electrical Engineering,
COMSATS Institute of Information Technology.

Abstract—This paper presents a circular patch antenna for WLAN applications with wideband characteristics. It is shown that impedance of the antenna is matched over wideband by using the partial ground plane and quarter wave transformer with slotted TX-Line. Ansoft HFSS is used for simulation tool to map the numerical results for the return loss frequency behavior of antenna. Measure of bandwidth, return loss and radiation pattern are also reported with satisfactory performance. As the patch is circular in shape so substrate is kept in the same shape. The shape of the substrate is also discussed in details for specific antenna designs.

IndexTerms—Wideband, Wireless, Microstrip, Substrate, bandwidth.

INTRODUCTION

Compact microstrip antenna is an intensive research topic in recent years. This is because of the demand of small and compact antennas for mobile communication. The work presented in this paper is to have a compact microstrip antenna design obtained by using partial ground plane and quarter wave transformer with slotted transmission line. Partial ground plane is used to increase the bandwidth of the antenna whereas the quarter wave transformer is used for impedance matching between the connector and antenna. The variation in the impedance throughout the covered band is controlled through a slot in the transmission line. This template provides authors with most of the formatting specifications needed for preparing electronic versions of their papers.

Wireless local area network has three specified bands i.e. 2.4GHz (2.4-2.484 GHz), 4.9GHz (4.9-5.1GHz) and 5.2GHz (5.15-5.35GHz). This antenna is specifically designed to operate at the center frequency that is 5.2GHz. The systems working in wideband range are of very importance. According to the specifications of FCC (Federal Communication Commission), wideband systems are those that specify the fractional bandwidth of greater than 20% and less than 50% [1]. The proposed design has a bandwidth of 39.7%. That can be easily considered as a wideband antenna.

ANTENNA DESIGN

The purpose of choosing circular patch configuration compared to a rectangular patch antenna is that a circular patch covers a less physical area than a rectangular patch. For this reason circular patch is used in designing arrays. Circular patch microstrip antenna consists of a circular patch placed on a dielectric substrate.

The design procedure is based on following formulae. The resonant frequency (f_r) for the dominant mode of propagation for a circular patch antenna is given by [2]:

$$f_r = \frac{1.8412v_o}{2\pi a\sqrt{\epsilon_r}} \quad (1)$$

This doesn't take fringing into account. Fringing is an effect that makes patch electrically larger. So, to consider fringing effect effective radius a_e is to be used in the formula.

Effective radius is given by formula [2],

$$a_e = a \left\{ 1 + \frac{2h}{\pi a \epsilon_r} \left[\ln \left(\frac{\pi a}{2h} \right) + 1.776 \right] \right\}^{1/2} \quad (2)$$

Replacing simple radius by effective radius in f_r equation, we have,

$$f_r = \frac{1.8412v_o}{2\pi a_e\sqrt{\epsilon_r}} \quad (3)$$

Now to find the radius a of the patch, we have,

$$a = \frac{F}{\left\{ 1 + \frac{2h}{\pi \epsilon_r F} \left[\ln \left(\frac{\pi F}{2h} + 1.776 \right) \right] \right\}^{1/2}} \quad (4)$$

Parameter includes, a is the radius of the patch, h is the height of the substrate, ϵ_r is the permittivity of the substrate used. F is given by formula [2].

$$F = \frac{8.791X10^9}{f_r\sqrt{\epsilon_r}} \quad (5)$$

For this antenna the f_r i.e. the resonant frequency is 5.2 GHz. The permittivity of the substrate is 4.7.

The radius of the patch comes to be 7.4mm. To make antenna compact and small in size partial ground plane as well as Quarter wave transformer is used [3]. This reduces the size of the antenna.

PHYSICAL DESCRIPTION

The antenna is printed on a standard FR4 substrate with thickness 1.6mm. This antenna is designed and simulated in Ansoft HFSS. The antenna is fed with 50Ω slotted transmission line. A partial ground is printed on the bottom side of the substrate. While designing the antenna the shape of patch, size and position transmission line and ground plane are

studied experimentally to achieve the loss under -10dB and maximum bandwidth.

The geometry of the antenna is shown in Fig.1.

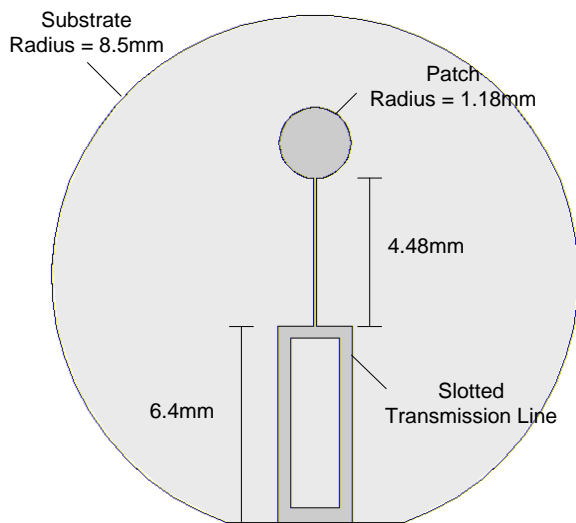

Fig.1. Dimensions of the patch and substrate (Front view)

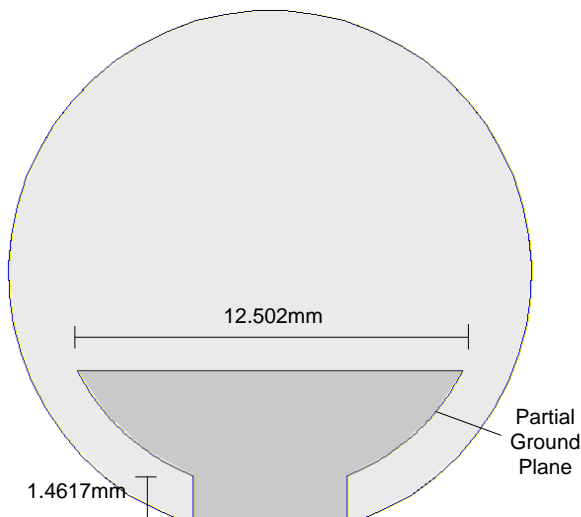

Fig.2. Dimension of Ground Plane (Rear View)

RESULTS AND DISCUSSION

In order to get the best impedance matching, quarter wave transformer [3] along with slotted TX-line is used. To achieve a better and larger bandwidth ground plane reduction or partial grounding is used [4]. The ground is also reduced from left and right side, this also adds to the bandwidth.

The main observation of the ground reduction is the distance of the ground below the patch [4]. The current distance is experimentally set for the best results to achieve maximum bandwidth.

Return Loss

Simulation and results of the design are shown by the characteristics of return loss. Simulation was carried out

between the frequency ranges of 1 to 10 GHz with a frequency step size of 10 MHz as it can be seen from Fig.3 that at resonant frequency of 5.18GHz it has a return loss of -46.44dB. It also provides the fractional bandwidth of 42.7%. That is good enough for a Wideband WLAN antenna.

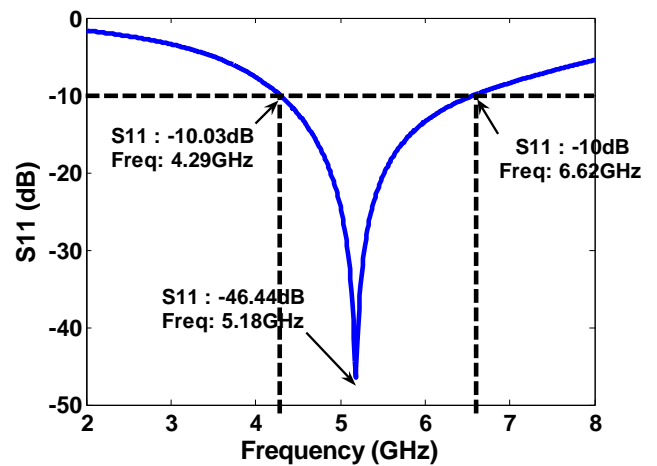

Fig.3. Return Loss Characteristics

As it can be seen from Fig.3 the band below -10dB is starting from 4.29 GHz to 6.62 GHz. It covers almost a band of 2.33 GHz. The range of Wireless LAN is from 4.9 to 5.1GHz and 5.15 to 5.35GHz. So the designed antenna covers two bands of WLAN applications.

Radiation Pattern

The radiation patterns of the antenna are shown. The simulations are carried out for frequency of 5.18 GHz. Far field radiation pattern of the design is taken at the planes XY, YZ and XZ.

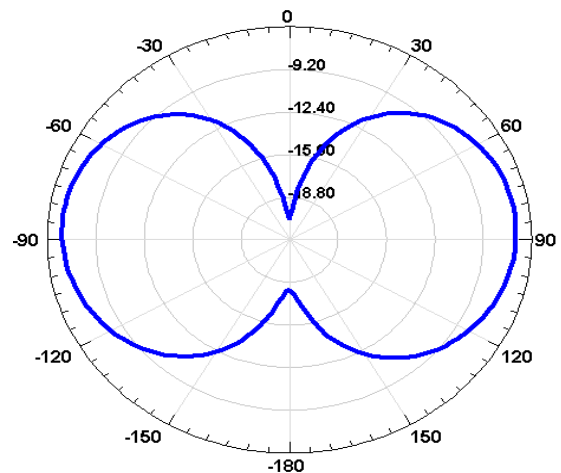

Fig.4. XY plot of radiation pattern at 5.18GHz

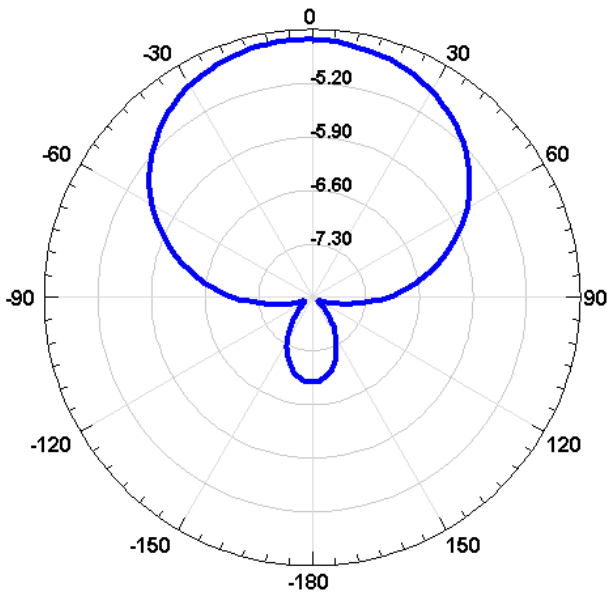

Fig.5. YZ plot of radiation pattern at 5.18GHz

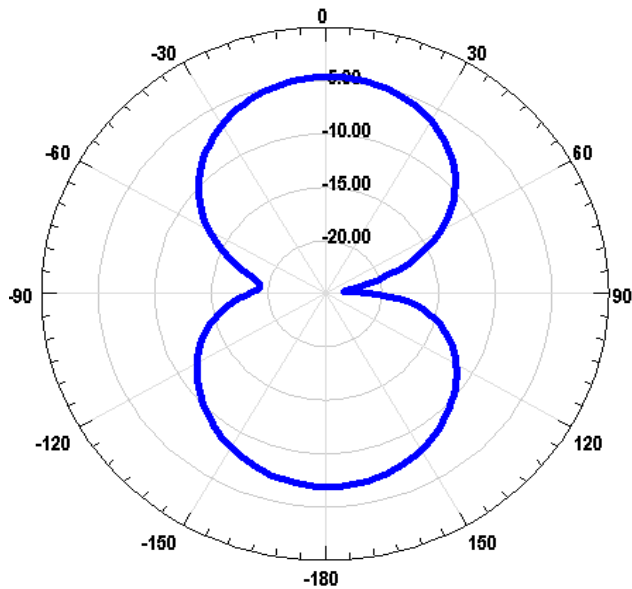

Fig.6. XZ plot of radiation pattern at 5.2GHz

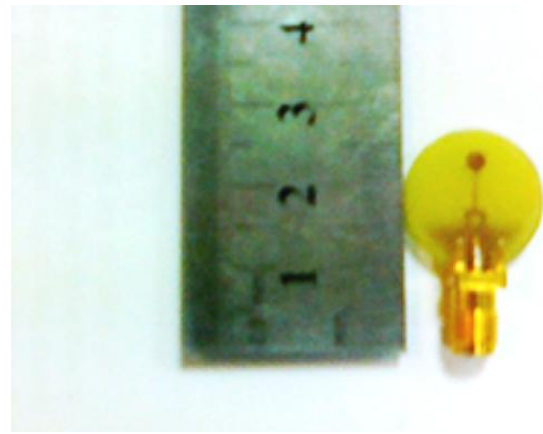

Fig.8. Fabricated Antenna

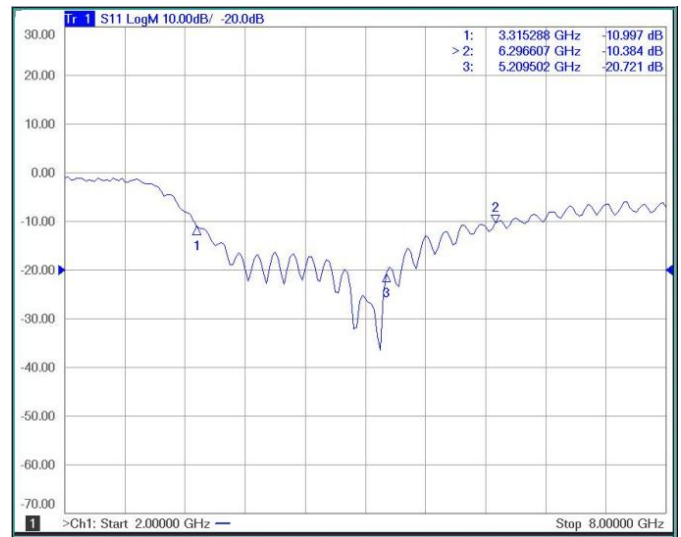

Fig.9. S11 plot of fabricated antenna

The measured results show that the fabricated antenna covers a band starting from 3.315 GHz to 6.29 GHz with return loss of -37dB at 5.18 GHz. The Fabricated antenna results are also shown in the Fig.9.

CONCLUSIONS

A circular patch antenna with circular substrate is designed and tested experimentally. Simulated and measured studies are performed. The return loss plots of both simulated and fabricated antenna are shown. The compactness and uniqueness of this design make it good for WLAN applications. The improvement of impedance matching was disused and verified. A large bandwidth patch antenna is obtained by ground reduction procedure and quarter wave transformer. This approach is clearly enhancing the bandwidth for WLAN.

REFERENCES

- [1] <http://www.antenna-theory.com/definitions/fractionalBW.php>

Fabricated Antenna and Results

The design is fabricated on FR4 substrate with $\epsilon_r=4.7$ and thickness 1.6mm. The compact size of the fabricated antenna is shown in Fig. 7. The whole size of the antenna is 2.5cm along with the connector. The connector used is SMA female connector 50 ohm. The antenna is tested with Agilent network analyzer. The results in term of return loss are shown in Fig. 8.

- [2] Constantine A. Balanis, *Antenna Theory-Analysis and Design*, Chapter 1, 2nd ed, John Wiley and Sons, Inc, 1997. Chapter 4, pp. 752 -756
- [3] Manoj Singh, AnanjanBasu, and S.K. Koul, "Circular Patch Antenna with Quarter Wave Transformer Feed for Wireless Communication", 2006 IEEE.
- [4] M.S. Karoui, H. Ghariani, M. Samet, M. Ramdani, R. Perdriau, "Bandwidth Enhancement of the Square /Rectangular Patch Antenna for Biotelemetry Applications" Vol.1-2010.
- [5] E. Wang, J. Zheng and Y. Liu, "A Noval Dual-Band Patch Antenna for WLAN Communication", 2009, Vol. 6, 93-102.
- [6] S.Sankaralingam, Bhaskar Gupta, "A Circular Disk Microstrip WLAN Antenna for Wearable Applications", 2009.
- [7] Abbaspour, M. and H. R. Hassani, "Wideband star-shapedmicrostrip patch antenna," Progress in Electromagnetics Research Letters, Vol. 1, 61/68, 2008.
- [8] Vibha Rani Gupta and Nisha Gupta, "Gain and Bandwidth Enhancement in Compact Microstrip Antenna."
- [9] M. Ali, R. Dougal, G. Yang and H.-S. Hwang, "Wideband Circularly Polarized MicrostripPatchAntenna for Wireless LAN Applications".
- [10] H. A. Osman, E. A. Abdallah, and A. A. Abdel Rhim, "A Novel Broadband Compact Circular Disk MicrostripAntennafor Wireless Applications", 2008, VOL. 4, NO. 7.
- [11] B.-K. Ang and B.-K. Chung, "A Wideband E-Shaped Microstrip Patch Antenna for 5-6GHZ Wireless Communication", 2007, PIER 75, 397-407.
- [12] Raheel M. Hashmi, Arooj M. Siddiqui, M.Jabeen, K. Shehzad, K.S.Alimgeer, "Design and Experimental Analysis of High Performance Microstrip Antenna for Wireless Broadband Communication", International Journal of Computer Science, Issues 2009.
- [12] K.S.Alimgeer, Shahid A. Khan, Z. Qamar, M. Zubair, Raheel M. Hashmi, "Parametric Trend Analysis of Miniature Slotted Antenna with Dual-Band Characteristics", 2nd IEEE Conference on Telecommunications CONATEL'11, Arequipa, Peru, May 2011.